

GIANTMIX FR STATIONARY

FR3 110-275
FR3 110-400
FR4 150-275
FR4 150-400
FR5 185-400



Application

Long-axis agitator for stationary installation
 Dry matter content up to 14 %
 Substrate temperature up to 70°C
 pH-value 6.5 - 8.2

Technical Data

Tube length 2.5 / 3.0 m
 Tube Ø 101.6 x 4.0 or 5.7 mm in ss304
 Sound pressure level 75 dB(A)
 Oil inspection glass for monitoring the tightness
 Option: Rubber compression seal Ø 200 mm, galvanized
 Optional PTO with protection unit for an alternative tractor operation
 Agitator completely in modular design
 POM protection to minimize abrasion

Motor

11.0 / 15.0 / 18.5 kW : 4 poles
 400 V, 50 Hz, special tensions on request
 PTC thermistors as overheat protection
 Ex-Motor (Series) II 3G Ex nA IIC T3 Gc
 Special version with 13.5 kW II 2G Ex eb IIC T3 Gb
 Optional: rain protection hood (ss304)

Gear

Spur gear drive, helical teeth, low noise level
 Reduction ratio $i = 3.69$ or 5.31
 Oil chamber, longlife gear oil
 Oil change interval after 2,000 operating hours

Bearing

2 tapered roller bearings to absorb the axial forces
 Mechanical seals in SiC/SiC, independant of rotation direction
 Interim bearings for the drive shaft, slide bearing

Propeller

3-blade high efficiency propeller, dynamically balanced

FR3:	11.0 kW	275 rpm	propeller HD+ 750
FR3:	11.0 kW	400 rpm	propeller HD+ 580
FR4:	15.0 kW	275 rpm	propeller HD+ 800
FR4:	15.0 kW	400 rpm	propeller HD+ 620
FR5:	18.5 kW	400 rpm	propeller HD+ 660

in ss304, ss316 or hardened steel

Ex-Zone

Ex-Zone 2 (outside the tank) and Zone 1 (inside the tank)
 Special version FR4 with 13.5 kW for Zone 1 (outside tank)
 Classification mechanical components:
 II 2G Ex h IIA T3 Gb

Control box

Star-delta-switch, soft starter, frequency converter
 Delivery without connecting cable

GIANTMIX FR STATIONARY

FR3 110-275
FR3 110-400
FR4 150-275
FR4 150-400
FR5 185-400

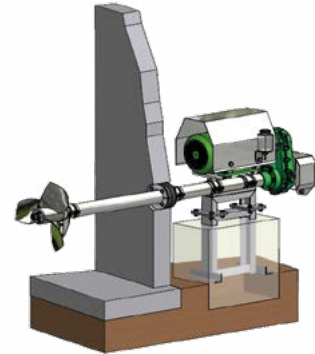
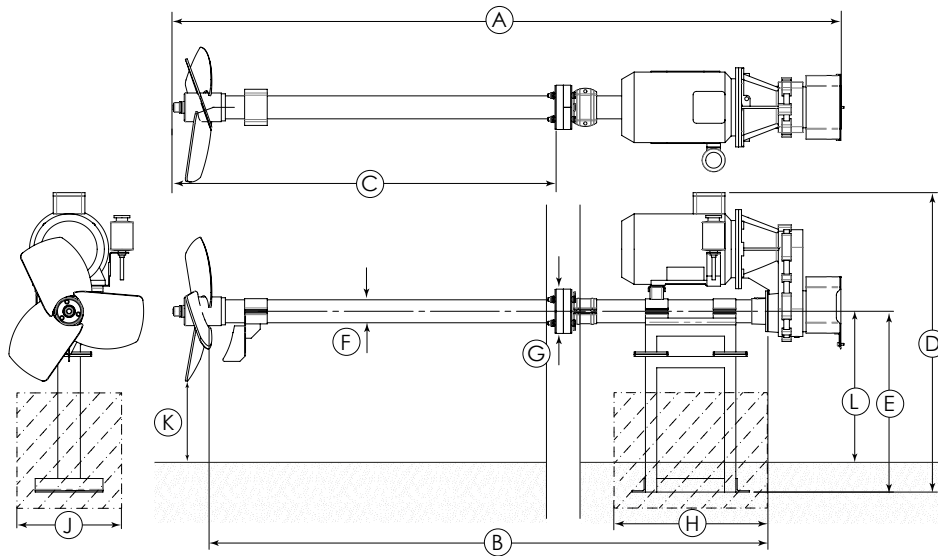

Dimensions

Type	A [m]	B [m]	C [m]	D [mm]	E [mm]	F [mm]	G [mm]	H [mm]	J [mm]	K [mm]	L [mm]
FR 3-5	3 / 3.5	2.5 / 3	1.6 / 2.1	1,325	800	101.6	200	800	500	min. 300	700

Technical data

Type	Rated Power [kW]	Propeller speed [rpm]	Rated Voltage [V]	Rated current [A]	Frequency [Hz]	Power factor cos ϕ	Gear reduction ratio	Propeller diameter [mm]	Axial force [kN]	Flow velocity [m/s] *	Pumping rate Water [m ³ /min]	Weight approximate [kg]
FR3	11.0	275	400	19.6	50	0.88	5.31	750	2.3	2.9	74	300
FR3	11.0	400	400	19.6	50	0.88	3.69	580	2.2	3.4	52	300
FR4	15.0	275	400	28.3	50	0.83	5.31	800	2.9	3.2	95	300
FR4	15.0	400	400	28.3	50	0.83	3.69	620	2.6	3.9	68	300
FR5	18.5	400	400	33.7	50	0.85	3.69	660	3.25	4.3	84	300

Subject to technical changes

* measured in water and 1.2 m distance